

DEPARTMENT OF THE ARMY TECHNICAL BULLETIN

CALIBRATION PROCEDURE FOR ELECTRONIC
VOLTMETER ME-227/U

Headquarters, Department of the Army, Washington, D.C.
11 October 1966

Section		Paragraph	Page
I.	GENERAL		
	Purpose and scope.....	1	1
	Reporting of technical bulletin improvements.....	2	1
	Description.....	3	1
	General instructions.....	4	3
	Differences among models.....	5	3
Section II.	CALIBRATION		
	Equipment required.....	6	3
	Preliminary procedure.....	7	3
	Mid-zero ranges.....	8	3
	10 mv and 25 mv ranges.....	9	5
	100 millivolt and up ranges.....	10	5
	Final procedure.....	11	7

SECTION I

GENERAL

1. Purpose and Scope. *a.* This bulletin provides information for the periodic calibration of Electronic Voltmeter ME-227/U fig. 1 and is used by maintenance calibration personnel. Since maintenance calibration personnel are trained and qualified in the usage of test and measuring equipment, detailed instructions concerning the operation and use of these equipments are not contain in this bulletin.

b. Integrated within this bulletin are illustrations delineating the location of all controls and components utilized in this calibration procedure as well as diagrams showing equipment setup. Equipment ground connections are not necessarily shown in the diagrams.

2. Reporting of Technical Bulletin Improvements. The direct reporting by the individual user or errors, omissions, and recommendations for improving this bulletin is authorized and encouraged. DA Form 2028 (Recommended Changes to DA Publications) will be used for reporting these improvement recommendations. This

form will be completed using pencil, pen, or typewriter and forwarded direct to Commanding General, U.S. Army Electronics Command, ATTN: AMSEL-MR-NMP-AD, Fort Monmouth, N.J. 07703.

3. Description. Electronic Voltmeter ME-227/U is a general-purpose instrument for measuring d-c voltages in the range of 1 millivolt to 1,000 volts. Additional data are listed in *a* through *c* below.

a. Identification.

Nomenclature MILLIVOLTMETER
ME-227/U.
Federal stock number..... 6625-892-5117.
Size..... 7 x 7 x 12 in.
Weight 25 lbs.
Reference TM 11-6625-610-15.

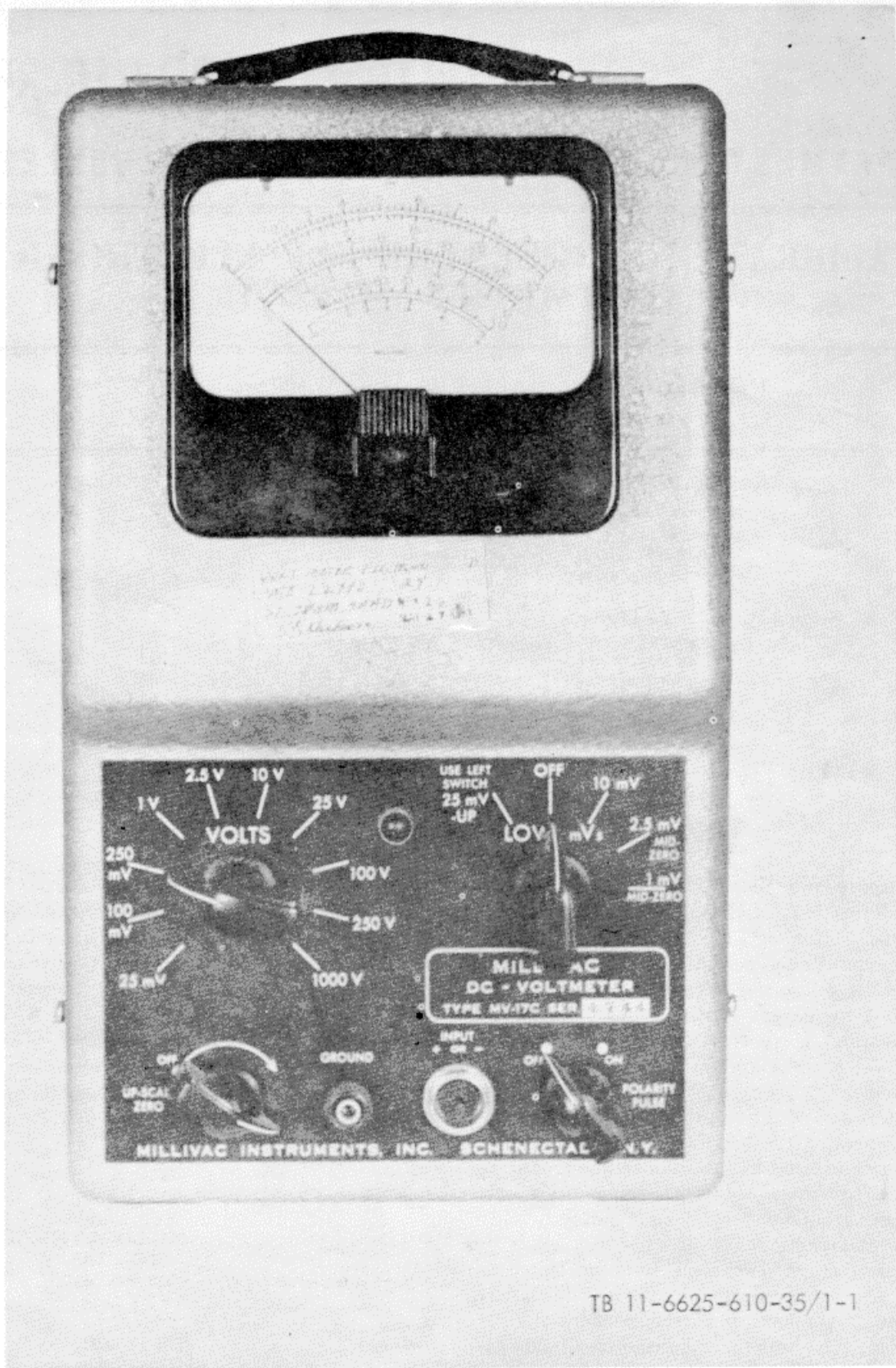

Figure 1. Electronic Voltmeter ME-227/U - front panel view.

b. Specifications.

Input requirements¹ 105-125 volts a-c, 60 cps single phase.
 Accuracy..... 3% full scale from 10 mv up 4% on lower ranges.
 Sensitivity..... 1 mv d-c, mid-zero.
 Total ranges 13 ranges, 1 mv and 2.5 mv mid-zero, 10 mv to 1,000 volts left-zero.
 Input impedance¹ 1 mv to 100 mv, 6 megohms 250 mv 16 megohms volt to 1,000 volts, left-zero.
 Zero drift¹ Less than 1% from 10 mv up, 3% on lower ranges.

c. Program Data.

Time required for calibration 2 hours (approx.).

Calibration level..... Maintenance.

¹ These specifications are for information only and

are not necessarily verified in this procedure.

4. General Instructions.

a. Calibration Reporting. During the performance of this procedure, annotate DA Form 2407 (Maintenance Request) in accordance with TM 38-750.

b. Frequency of Calibration. The maximum time permitted between calibration checks for Millivoltmeter ME-227/U is contained in TB 11-6625-692-15/1.

c. Reporting Requirements. Report accomplishment of maintenance level calibration only when required as instructed in TB 11-6625-692-15/1.

d. Unit Under Test. Millivoltmeter NME-227/U will be referred to as "unit under test."

e. Removal. Do not remove the unit under test from its protective case unless necessitated by equipment connections and/or components to be adjusted which are not accessible from external ports provided on the unit under test.

5. Differences Among Models. None.

**SECTION II
CALIBRATION**

6. Equipment Required. Equipment required for calibration performance checks and adjustments is listed in table 1. When any of the equipment listed in table 1 is not available, equivalent calibrated item may be used.

Table 1. Equipment Required for Calibration Performance Checks and Adjustments

A. Authorized Calibration Equipment

Nomenclature	Federal stock No.
DECADE RESISTOR ZM-16/U ¹	6625-669-0266
ELECTRONIC VOLTMETER ME-202/U	6625-709-0288
METER TEST SET TS-682/GSM-1	6625-669-0747

¹ Two required.

B. Authorized Accessories

Nomenclature	Federal stock No.	Description
ADAPTER ¹	4931-739-4416	Single banana jack to spade lug.
ELECTRICAL LEAD ²	4931-739-4432	24-inch single banana jack terminations.

¹ Four required.

² Two required.

Note. It is recommended that personnel familiarize themselves with the entire procedure prior to performing

calibration.

7. Preliminary Procedure.

a. Remove rear cover from unit under test.

b. Adjust meter zero adjustment screw if required.

c. Connect equipment to 115 vac bench power; energize, and allow 15 minutes for warmup and stabilization.

Warning: Because of wiring, rear cover of unit under test cannot be removed completely. Therefore, use CAUTION when making adjustments to prevent contact with fuse holder which is at 115 vac potential.

Note. The following paragraphs are divided into subparagraph *a*, performance check, and subparagraph *b*, adjustments. When the performance check is within tolerance, do not perform the corresponding adjustment. When the performance check is not within tolerance, perform the corresponding adjustment before continuing with the calibration procedure. When the performance check is not within tolerance and no adjustment is specified, the deficiency must be corrected before continuing with the procedure.

8. Mid-zero Ranges.

a. Performance Check.
 (1) Connect equipment as shown in figure 2.
 (2) Position controls on unit under test as listed in (a) through (c) below.

(a) LOW MVS switch to 1 MV MID-ZERO.

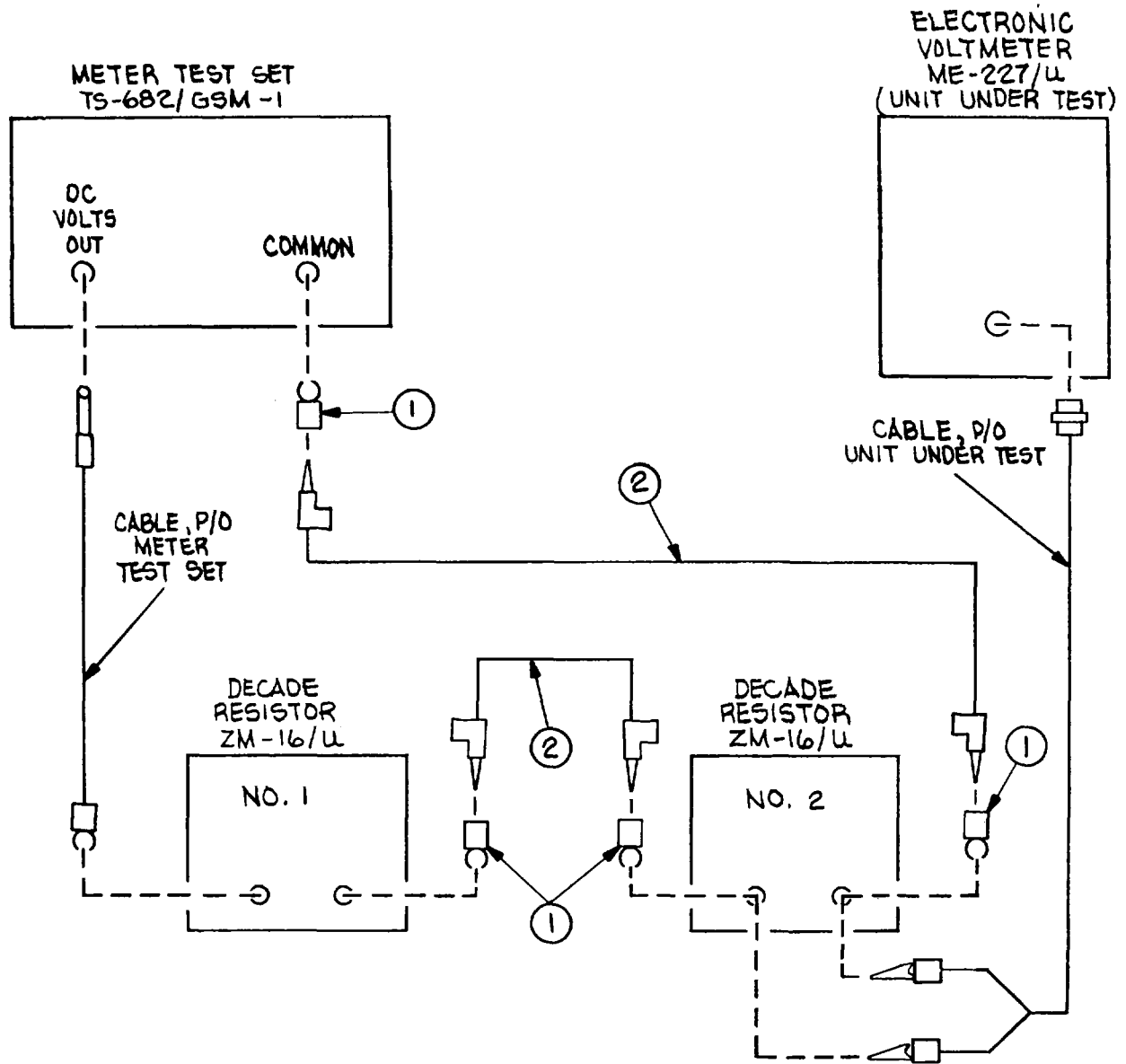

ITEM NO.	NOMENCLATURE	FEDERAL STOCK NO.	QTY
①	ADAPTER	4931-739-4416	4
②	ELECTRICAL LEAD	4931-739-4432	2

TAGO 640A

Figure 2. Electronic Voltmeter ME-227/U - mid-zero ranges check, equipment set-up.

(b) POLARITY PULSE to OFF.

(c) UP SCALE ZERO for center-scale 0 indication.

(3) Adjust Decade Resistor, ZM-16/U number 1 to 990 ohms and decade resistor number 2 to 10 ohms.

(4) Adjust d-c output of Meter Test Set TS-682/GSM-1 to 100 millivolts.

(5) Adjust decade resistor number 2 for 1 mv (full scale) indication on unit under test. (Setting of decade resistor number 2 should be between 9.6 and 10.4 ohms.)

(6) Adjust decade resistor number 2 to 0 ohms.

(7) Turn LOW MVS switch on unit under test to 2.5MV MID-ZERO and adjust UP SCALE ZERO for center scale 0 indication on meter of unit under test.

(8) Adjust decade resistor number 1 to 975 ohms and decade resistor number 2 for 2.5 MV (full scale) indication on unit under test. (Setting of decade resistor number 2 should be between 24.0 and 26.0 ohms.)

b. Adjustments.

(1) If indication obtained in a(5) is not within limits, repeat a(1) through (4).

(2) Adjust LMV MID-ZERO Potentiometer (fig. 3) for 1 MV (full scale) indication on unit under test.

(3) If indication obtained in a(8) above is not within limits, repeat a(6) and (7).

(4) Adjust decade resistor number 1 to 975 ohms and decade resistor number 2 to 25 ohms.

(5) Adjust 2.5 MV MID-ZERO potentiometer (fig. 3) for 2.5 MV (full scale) indication on unit under test.

9.10 Mv and 25 Mv Ranges. a. Performance Check.

(1) Connect equipment as shown in figure 4.

(2) Position controls on unit under test as listed in (a) through (c) below.

(a) LOW MVS switch to 10 MV.

(b) UP SCALE ZERO to OFF.

(c) VOLTS to 25 MV.

(3) Adjust meter test set for 10-millivolt indication on unit under test.

(4) Indication on Electronic Voltmeter ME-202/U should be between 9.7 and 10.3 millivolts.

(5) Turn LOW MVS switch on unit under test to USE LEFT SWITCH 25 MV-UP.

(6) Adjust meter test set for 25-millivolt indication on unit under test.

(7) Indication on Electronic Voltmeter should be between 24.25 and 25.75 millivolts.

b. Adjustments.

(1) Repeat a(1) and (2).

(2) Adjust d-c output of meter test set for 10 millivolt indication on electronic voltmeter.

(3) Adjust left zero 10MV AND UP potentiometer (fig. 3) for 10-millivolt indication on unit under test.

10. 100 Millivolt and Up Ranges. a. Performance Check.

(1) Connect d-c output of meter test set to input leads of unit under test.

(2) Position unit under test LOW MVS switch to USE LEFT SWITCH 25 MV-UP and VOLTS switch as listed in table 2.

(3) At each setting listed in table 2, adjust d-c output of meter test set for indications on unit under test as listed in table 2. Indications on meter test set will be within limits specified in table 2.

Table 2 100-Millivolt and Up Ranges

Unit under test		Meter test set indication (volts dc)	
Volts setting	Meter indication	Min.	Max.
100mV	10	0.097	0.103
250mV	25	0.243	0.258
1V	4	0.37	0.43
1V	6	0.57	0.63
1V	8	0.77	0.83
1V	10	0.97	1.03
2.5V	25	2.42	2.58
10V	10	9.7	10.3
25V	25	24.2	25.8
100V	10	97	103
250V	25	242	258
1,000V	10	970	1030

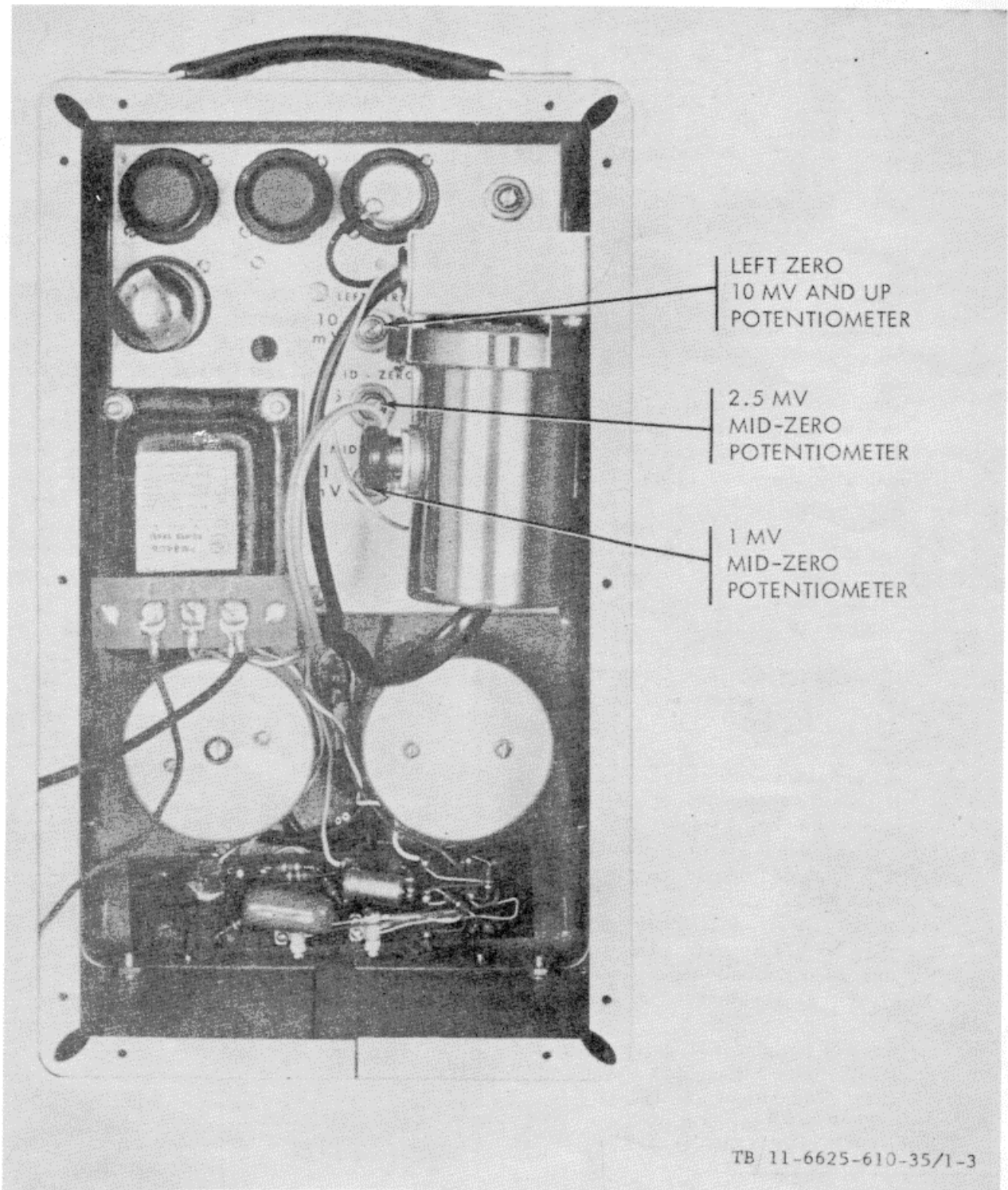

TOGA 640A

Figure 3. Electronic Voltmeter ME-227/U - rear view.

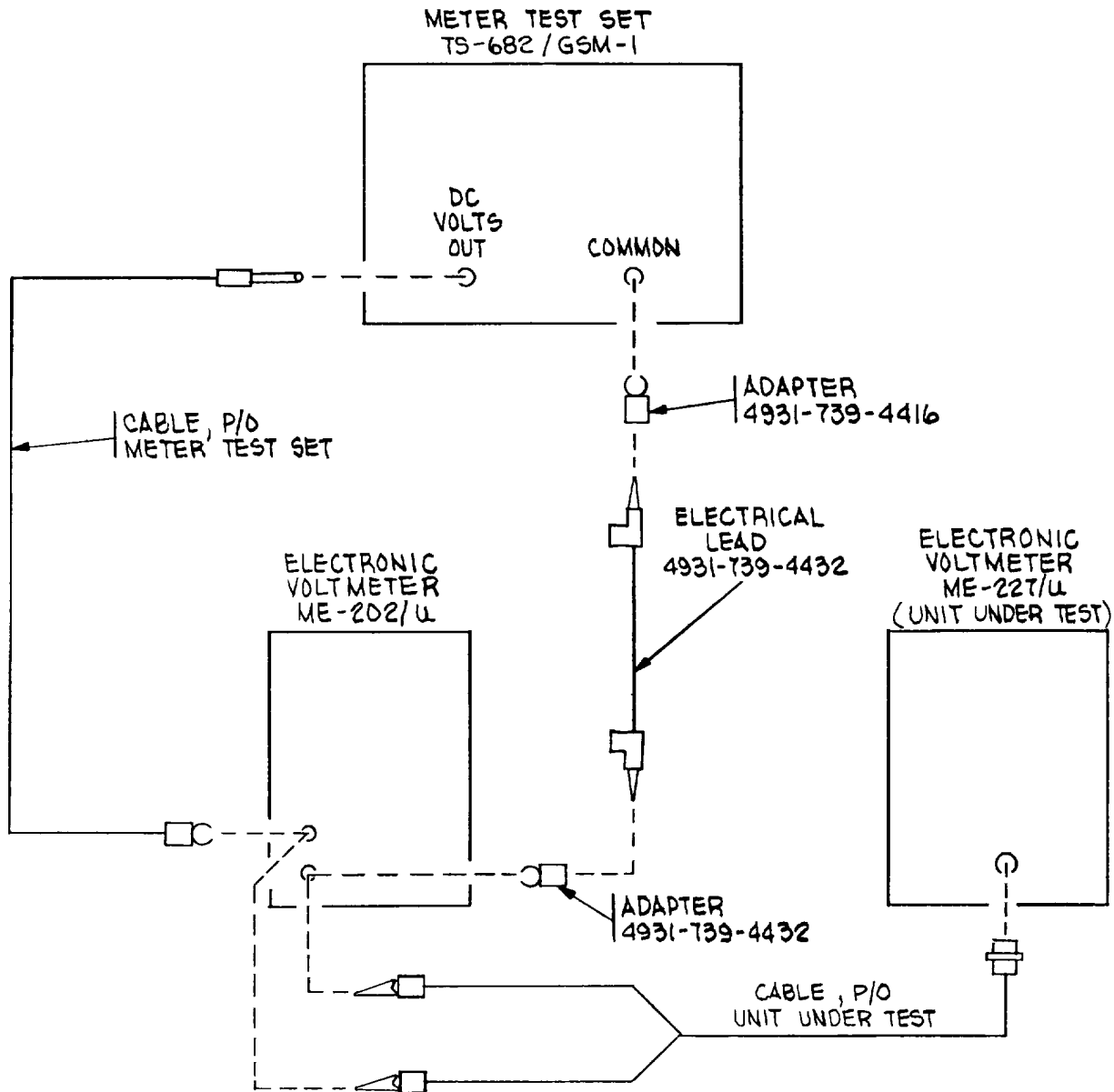

TB 11-6625-610-35/1-4

Figure 4. Electronic Voltmeter ME-227/U - 10 mv and 25 mv ranges check, equipment setup.

b. Adjustments.

- (1) Adjust left zero 10 mV AND UP potentiometer (fig. 3) for indications within limits listed in table 2.
- (2) If adjustment is required, repeat steps in 9a, adjusting 10mV AND UP potentiometer for optimum results in both step 9a and 10a.

11. Final Procedure. a. Deenergize and disconnect all test equipment, and install rear cover on unit under test.

b. In accordance with TM 38-750, annotate and affix calibration DA Label 80 (U.S. Army Calibration System). When the unit under test cannot be adjusted to within tolerance, annotate and affix DA Form 2417 (Unserviceable Test Instrument or Standard) (red tag).

TOGA 640A

By Order of the Secretary of the Army:

HAROLD K. JOHNSON,
General, United States Army,
Chief of Staff.

Official:

KENNETH G. WICKHAM,
Major General, United States Army,
The Adjutant General.

Distribution:

Active Army:

USASA (2)	USAMUCOM (2)	Gen Dep (2)
CNGB (1)	USAWECOM (2)	Sig Sec, Gen Dep (5)
CC-E (7)	USAMOCOM (2)	Sig Dep (12)
Dir of Trans (1)	USATECOM (2)	Army Dep (5) except
CofEngrs (1)	USASTRATCOM (4)	LBAD (20)
TSG (1)	USAESC (85)	SAAD (35)
CofSptS(1)	MDW (1)	TOAD (20)
USACDCEA (1)	Armies (2)	LEAD (20)
USACDCCBRA (1)	Corps (2)	TEAD (17)
USACDCCEA (1)	USAC (3)	ANAD (17)
USACDCOA (1)	USATC (2)	PUAD (17)
USACDCQMA (1)	Svc Colleges (2)	SigFLDMS (2)
USACDCTA (1)	USASCS (20)	AMS (1)
USACDCADA (1)	USASESCS (40)	USACCREL (2)
USACDCARMA (1)	USAADS (2)	USAERDAA (2)
USACDCAVNA (1)	USAAMS (2)	USARERDAW (13)
USACDCARTYA (1)	USAARMS (2)	Units organized under following
USACDCSWA (1)	USAIS (2)	TOE'S:
USACDCCEA, Ft Huachuca (1)	USAES (2)	11-57 (2) 11-500
USAARENBD (2)	USAOC&S (40)	11-97 (2) (AA-AC)
USAMC (5)	WRAMC (1)	11-98(2) (2)
USCONARC (5)	Army Pic Cen (2)	11-117 (2) 11-587 (2)
ARADCOM (5)	Instl (2) except	11-155 (2) 11-592 (2)
ARADCOM Rgn (2)	Ft Gordon (10)	11-157 (2) 11-597 (2)
OS Maj Comd (4)	Ft Huachuca (10)	11-158 (2) 29-56 (2)
LOGCOMD (2)	Ft Carson (21)	29-134 (10)
USAMICOM (4)	Ft Knox (12)	

NG: State AG (3).

USAR: None.

For explanation of abbreviations used see AR 320-50.

TOGA 640A

*U.S. GOVERNMENT PRINTING OFFICE: 1989 0-242-451 (5292)

RECOMMENDED CHANGES TO EQUIPMENT TECHNICAL PUBLICATIONS



THEN... JOT DOWN THE DOPE ABOUT IT ON THIS FORM, CAREFULLY TEAR IT OUT, FOLD IT AND DROP IT IN THE MAIL!

SOMETHING WRONG WITH THIS PUBLICATION?

FROM: (PRINT YOUR UNIT'S COMPLETE ADDRESS)

DATE SENT

PUBLICATION NUMBER

PUBLICATION DATE

PUBLICATION TITLE

BE EXACT... PIN-POINT WHERE IT IS

PAGE NO.	PARA-GRAPH	FIGURE NO.	TABLE NO.
----------	------------	------------	-----------

IN THIS SPACE TELL WHAT IS WRONG AND WHAT SHOULD BE DONE ABOUT IT:

TEAR ALONG PERFORATED LINE

PRINTED NAME, GRADE OR TITLE, AND TELEPHONE NUMBER

SIGN HERE:

DA FORM 2028-2
1 JUL 79

PREVIOUS EDITIONS ARE OBSOLETE.

P.S.—IF YOUR OUTFIT WANTS TO KNOW ABOUT YOUR RECOMMENDATION MAKE A CARBON COPY OF THIS AND GIVE IT TO YOUR HEADQUARTERS.

PIN: 014374-000